

NUMBER: SB 550-32-005, Rev B  
MODEL: ECLIPSE EA550  
SUBJECT: Wheel Speed Transducers (WST) Inspection & Repair

**Recommended**

[www.ECLIPSE.aero](http://www.ECLIPSE.aero)

## 1. PLANNING INFORMATION

### A. Effectivity

Aircraft Serial Numbers: 550-0263 to 550-0265, 550-0268 to 550-0280, 550-0282 to 550-0284 and 550-1001 to 550-1013.

### B. Applicability

Aircraft with Wheel Speed Transducers (WST) part number D202106.

### C. Reason

This bulletin inspects, tests, and repairs (if necessary) the Wheel Speed Transducers (WST) part number D202106.

Revision B of this Service Bulletin updates WST Functional Test.

### D. Description

There are two WSTs installed on the aircraft, one on the left Main Landing Gear Wheel and one on the right Main Landing Gear Wheel.

This Service Bulletin provides procedures to inspect, test and repair (if necessary) the WST on an Eclipse aircraft.

### E. Relevant Publications

06-123838, EA550 AMM, current revision

### F. Compliance

Eclipse Aerospace Incorporated considers this to be a recommended procedure.

Compliance with revision A constitutes compliance with revision B.

### G. Approval

This Service Bulletin is based on engineering data that is FAA-approved, and the modification herein complies with the applicable regulations.

### H. Labor Requirements

The following information is for planning purposes only.

#### (1) Estimated labor hours to perform:

Suggested number of personnel: 2 (3, if jacking both Main Landing Gear together)

Test: 4 Hours (2 Hours per wheel)

Repair: 1 Hour + 24 Hours adhesive cure time

The above is an estimate based on properly equipped and experienced personnel complying with this Service Bulletin. Actual labor hours may vary depending on workforce experience, concurrent maintenance, discovery of other discrepancies, etc.

(2) Qualification of personnel:

- A person properly authorized under 14 CFR 43 to perform aircraft maintenance.

I. Weight and Balance Change

N/A

J. Electrical Load Data Change

N/A

K. Software Accomplishment Summary

N/A

L. References

06-123838, EA550 AMM, current revision

M. Publications Affected

N/A

N. Export Control

These commodities, technology or software were exported from the United States in accordance with the Export Administration Regulations. These commodities, technology or software are intended for use only in the End User's country. An export license from the U.S. Department of Commerce may be required before these products can be re-exported, transferred, transshipped on a non-continuous voyage, or otherwise disposed of in any other country, either in their original form or after being incorporated into an end item. Diversion of this end-item or its use contrary to any applicable U.S. government license or to U.S. law is prohibited.

## 2. MATERIAL INFORMATION

### A. Materials

None

### B. Consumables

The following consumables are required for this Service Bulletin.

Material	Specification	Use
Adhesive	Loctite 415	WST repair
Thread Locker	Loctite 222MS	Wheel fairing installation
Solvent	Denatured Alcohol	Parts cleaning
Pipe Cleaners	Commercially Available	Parts cleaning
Swabs	Cotton	Parts cleaning
Bore Brush	Brass, 0.125 in diameter	Parts cleaning

### C. Tooling

The following special tooling/support equipment is required to accomplish this Service Bulletin

Nomenclature	Specification	Use
Gauge, Push-Pull	0–100 lbs Shimpo MF-100 or equivalent	Pull Test
Clamp	Kant Twist 401 or equivalent	Pull Test
Power Supply	Capable of 5 VDC regulated and 500mA output	Functional Test
Jack, Main, 2 each <sup>[1]</sup>	Tronair 02-0517-0140 or equivalent	Functional Test
Jack, Tail, 1 each <sup>[1]</sup>	Tronair, 02-0522-0140) or equivalent	Functional Test
Single Point Jack Adapter <sup>[2]</sup>	32T104910-MIT-002	Functional Test
Multimeter	RMS	Functional Test
Test Leads and Adapters	Various test leads and adapters for the power supply and multimeter	Functional Test
Breakout Box, ABS/WST	87-125314-(-)	Functional Test

[1] Use if jacking both aircraft main landing gear together.

[2] Use if jacking each main gear individually

### D. Cost

Contact Eclipse Aerospace Customer Care for cost information and availability.

## 3. ACCOMPLISHMENT INSTRUCTIONS

### A. Job Set-Up

- (1) Make aircraft safe for maintenance. Refer to AMM 20-00-01 – MAKE SAFE FOR MAINTENANCE.
- (2) Remove passenger seat. Refer to AMM-25-21-10-001-801 – Passenger Seat - Removal.
- (3) Remove 131 AZ - Floor Panel, Forward Left Cabin. Refer to AMM-06-50-00-051-801 – Aircraft Access Panels.
- (4) Remove left and right main landing gear wheel fairings as follows:
  - (a) Remove the three screws that attach the fairing to the outboard wheel half.
  - (b) Remove the wheel fairing.
  - (c) Remove the drive cap.

### B. WST Pull Test

Refer to [Figure 1](#), [Figure 2](#), and [Figure 3](#).

- (1) Attach Kant Twist clamp on to the WST shaft. Hand tighten clamp only.

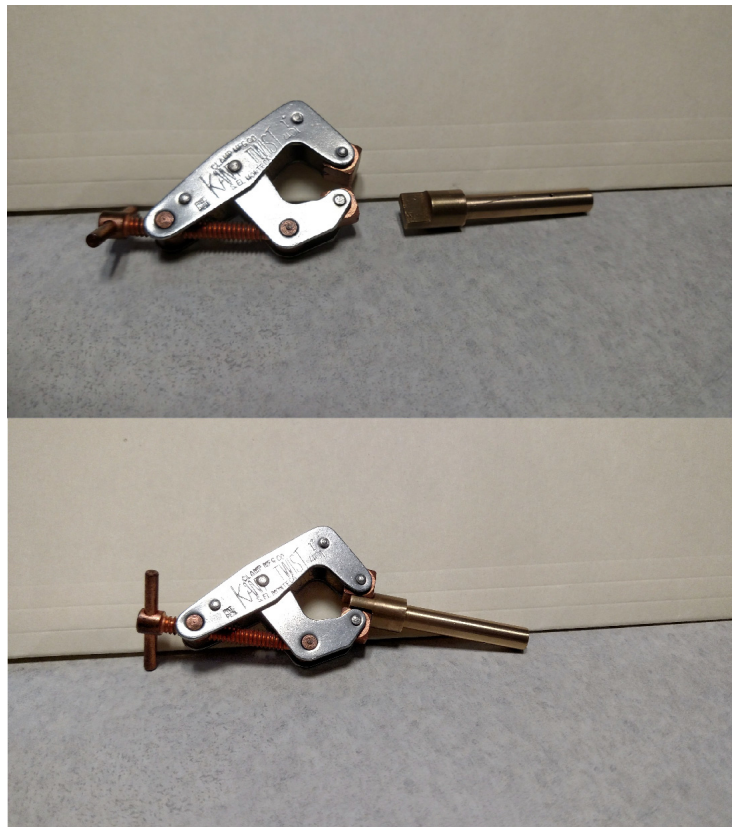

**Figure 1. WST Pull Test Components**

- (2) Connect push/pull force gauge using large accessory hook to through clamp's center.



**Figure 2. WST Pull Test Setup**

- (3) Gradually pull push/pull force gauge in an outboard direction while maintaining a direction of pull parallel to the shaft to obtain a force of approximately 10 lbs. Maintain force at 10 lbs +/- 1 lb for 10 seconds.
  - (a) WST shaft does not move laterally.
  - (b) If WST pulls out of bore, proceed to repair section.
- (4) Slowly release force on push/pull gauge.

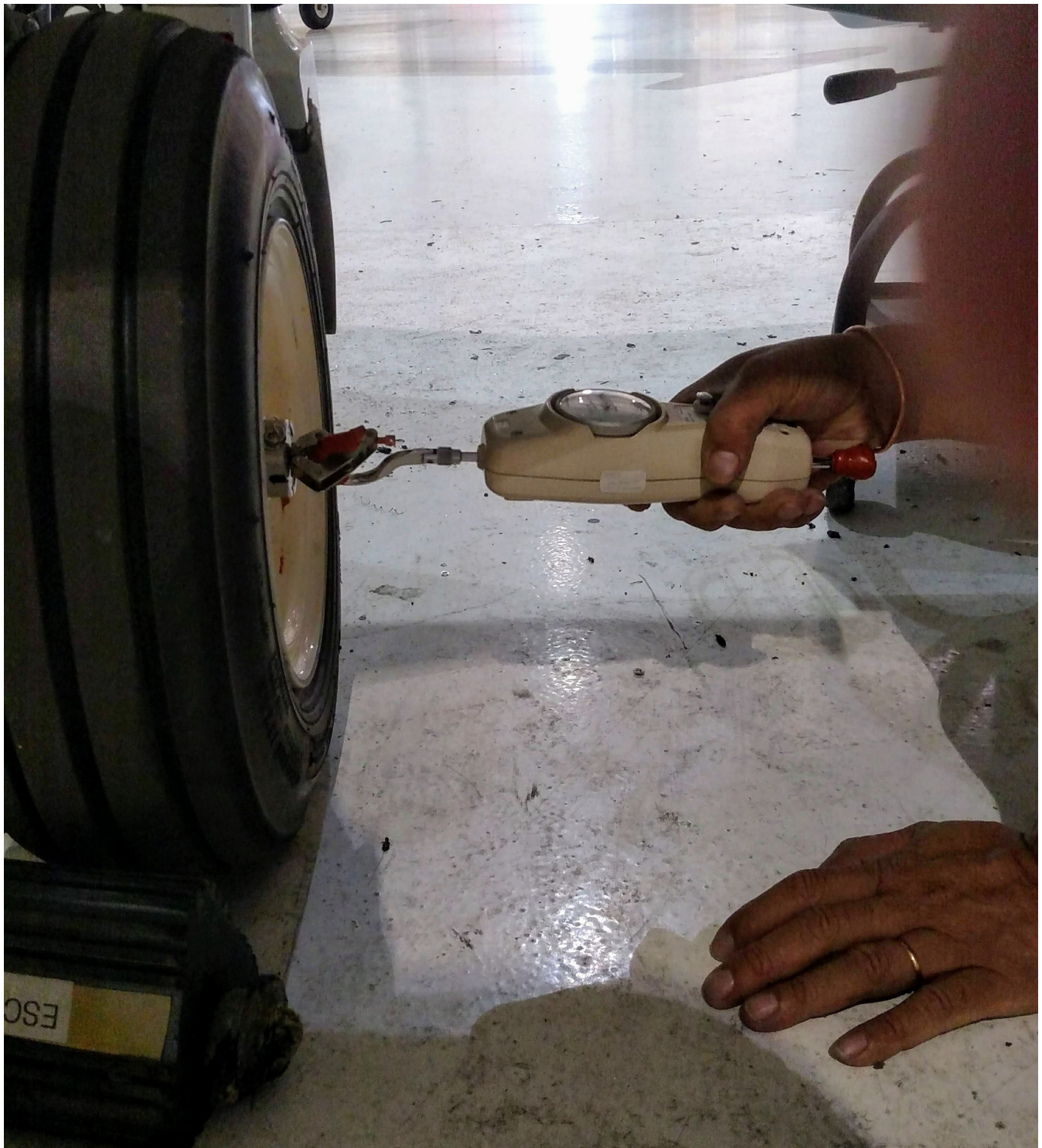
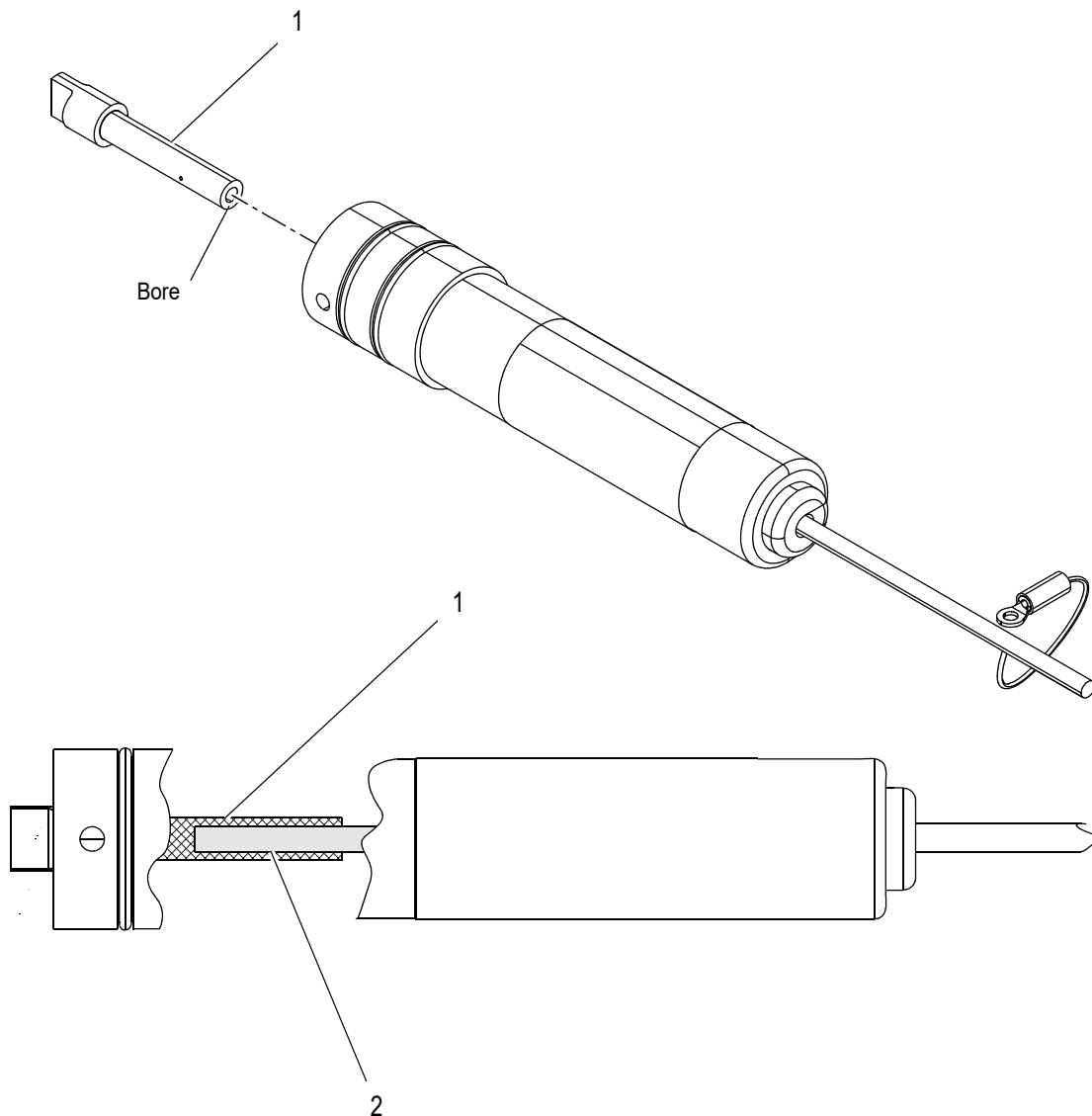

**Figure 3. WST Pull Test**

## C. WST Repair

Refer to Figure 4.

- (1) Clean the bore of wheel speed transducer shaft (1) with pipe cleaners, bore brush, and cotton swabs soaked with alcohol. Allow to dry.
- (2) Apply one or two drops of Loctite 415 into the bore of the wheel speed transducer shaft (1). Carefully place the wheel speed transducer shaft (1) on to the wheel speed transducer (2) until the shaft bottoms out.
- (3) Allow 24 hours for Loctite 415 to cure before performing WST Functional Test.



5202058A

**Figure 4. Wheel Speed Transducer Repair**

## D. WST Pull Test/Repair Job Closeup

- (1) Install left and right main landing gear wheel fairings as follows:

Refer to Figure 5.

- (a) Align the drive tab (7) on the WST with the slot of the drive cap (6), and carefully align the standoffs into position with the wheel assembly (1) tapped holes. Slight pressure on the drive cap (6) should be enough to secure the drive cap (3) into place.
- (b) Install wheel fairing (3) onto the outboard wheel half with three screws (5) Applying Loctite removable thread locker (222MS) to the three screws (5) prior to installation. Make sure that the servicing panel (4) on the wheel fairing is located over the wheel valve stem (2).
- (c) Torque the three screws (5) to 35-45 lbf.in (4.0-5.0 Nm).

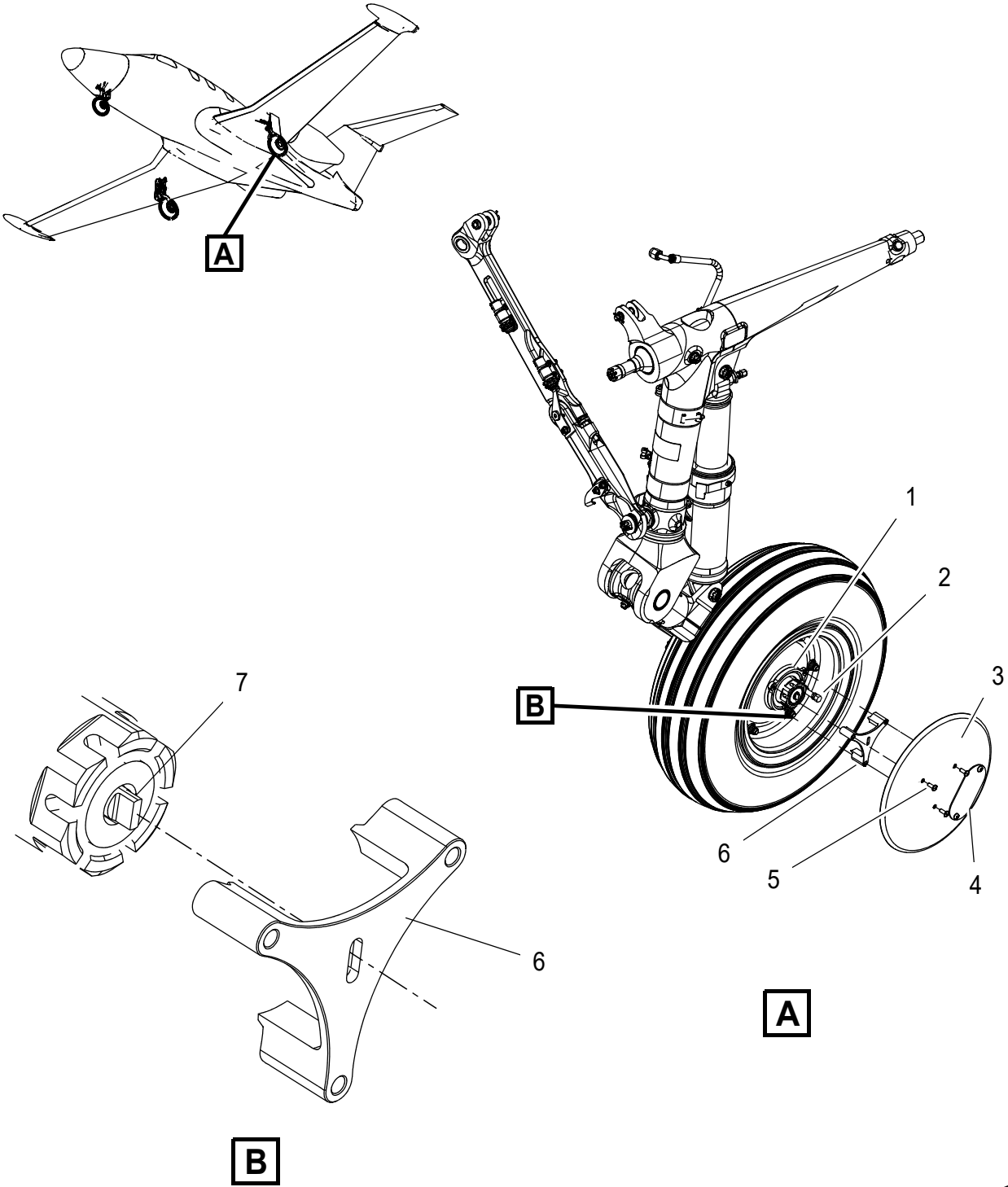

5202057A

Figure 5. Wheel Speed Transducer Drive Cap Installation

## E WST Functional Test Setup

- (1) Jack the aircraft to remove weight from landing gear, wheels and tires. Refer to AMM-07-10-00-051-801 – Jacking - Maintenance Practices.

NOTE: Single point jacking is an acceptable alternative. Each WST will need to be tested individually.

There are three setup methods of testing that can be used. Anyone of the three methods is acceptable.

### Method 1

- (1) ABS/WST Breakout Box, p/n 87-125314-() connected to ships harness and DECU.

(a) Setup ABS/WST Breakout Box as follows:

1. Set Breakout Box switch to EXTERNAL POWER. Refer to [Figure 6](#).
2. Connect J01 [Figure 7](#), (5) to ships harness 32A30P01 [Figure 7](#), (4).
3. Connect P01 [Figure 7](#), (2) to DECU [Figure 7](#), (1).
4. Set RMS Multimeter function to DC volts.
5. Connect RMS Multimeter negative lead to Breakout Box jack labeled COM GND. Refer to [Figure 6](#).
6. Connect RMS Multimeter positive lead to Breakout Box jack labeled 5VDC. Refer to [Figure 6](#).
7. Apply external power to the aircraft. Refer to AMM-24-40-00-051-801 – External Power - Maintenance Practices.
8. RMS Multimeter should read above 3 volts. If not, confirm that DECU is powered by checking ECBs and associated aircraft wiring. If DECU is powered, replace faulty DECU, refer to AMM-32-41-17 -Digital Electronic Control Unit - Removal/Installation.

NOTE: A faulty DECU will cause both WSTs to fail the functional test

9. Set Breakout Box switch to INTERNAL POWER. Refer to [Figure 6](#).
10. Connect RMS Multimeter positive lead to Breakout Box jack labeled WST SIG (L or R) which ever WST is under test. Refer to [Figure 6](#).

NOTE: Both the left and right WST can be monitored simultaneously by using two RMS Multimeters.

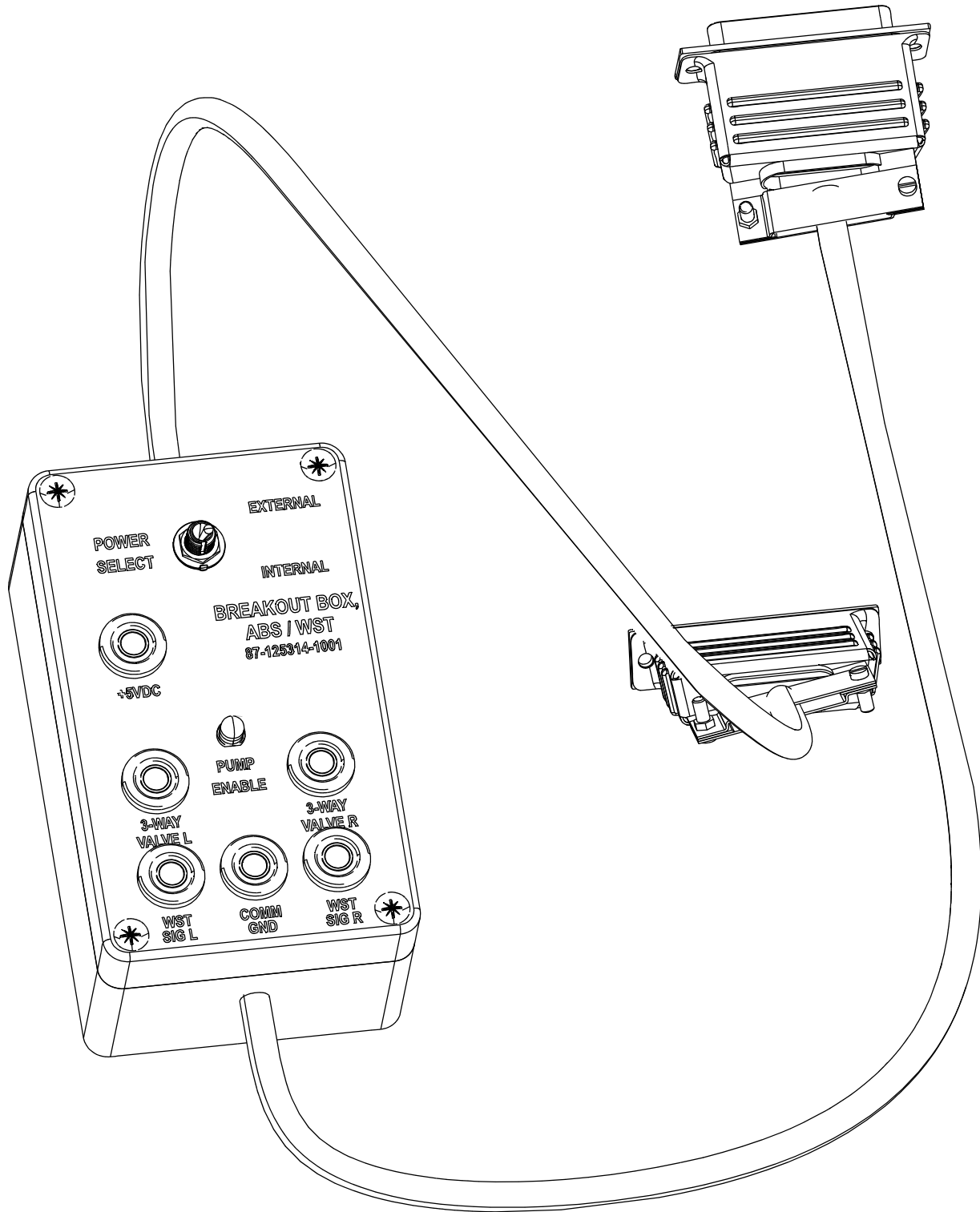

5202055A

Figure 6. ABS/WST Breakout Box, p/n 87-125314-()

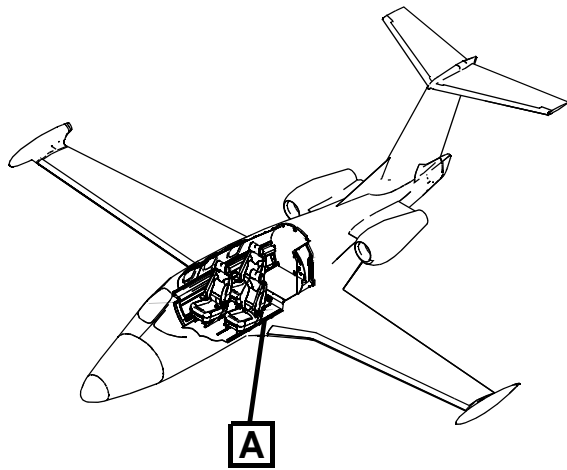

**LEGEND**

- 1 DECU
- 2 DECU J01/Breakout Box P01
- 3 Breakout Box
- 4 32A30P01
- 5 Breakout Box J01

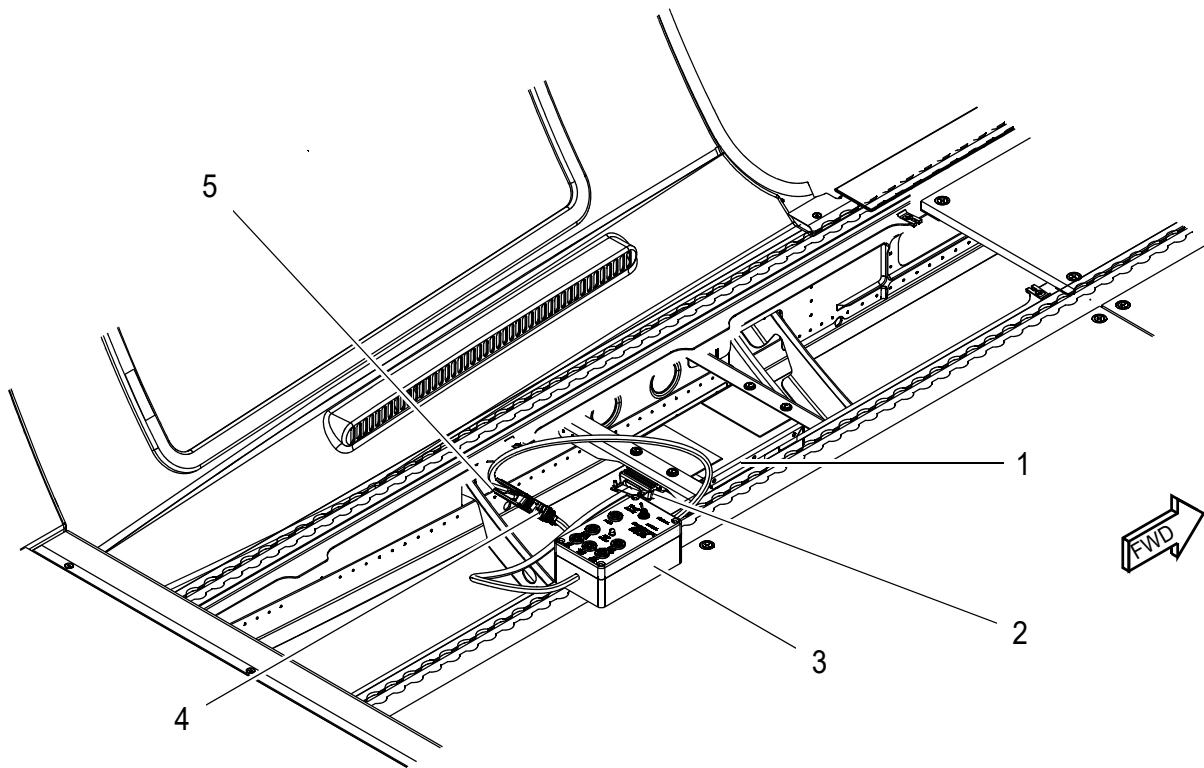

**A**

(ROTATED FOR CLARITY)

**Figure 7. ABS/WST Breakout Box connected to DECU**

5202054A

## Method 2

- (1) ABS/WST Breakout Box, p/n 87-125314-() connected to ships harness only.

Refer to [Figure 8](#).

- (a) Setup ABS/WST Breakout Box as follows:

CAUTION: DO NOT EXCEED WST VOLTAGE RANGE  $5.0 \pm 0.3$  VOLTS. DAMAGE TO THE WST CAN OCCUR.

1. Setup power supply (1) for output of +5VDC. Turn off power supply before connecting to the ABS/WST Breakout Box.
2. Connect power supply (1) positive lead (2) to Breakout Box +5VDC banana jack (red).
3. Connect power supply ground (3) to Breakout Box COM GND banana jack (blk).
4. Set Breakout Box switch to EXTERNAL POWER.
5. Connect Breakout Box J01 (4) to ships harness 32A30P01 (5).
6. Leave Breakout Box P01 disconnected and isolate to prevent electrical contact with conductive materials.
7. Connect RMS Multimeter negative lead to Breakout Box COM GND.
8. Connect RMS Multimeter positive lead to Breakout Box WST SIG (L or R) which ever WST is under test

NOTE: Both the left and right WSTs can be monitor simultaneously by using two RMS Multimeters.

9. Set RMS Multimeter function to DC volts.
10. Turn power supply on.

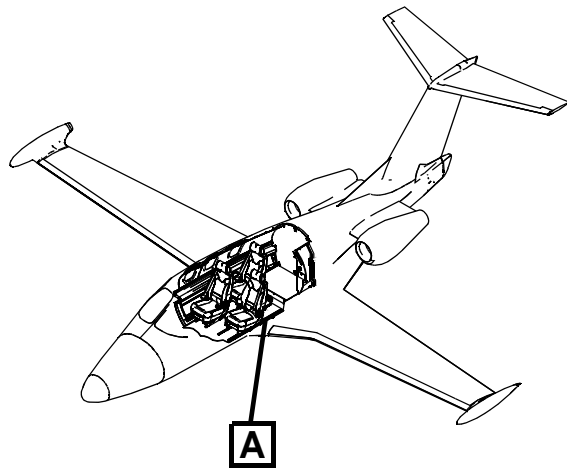

**LEGEND**

- 1 +5VDC Power Supply
- 2 Positive Power Supply Lead
- 3 Negative Power Supply Lead
- 4 Breakout Box
- 5 Breakout Box J01/Ships Harness 32A30P01
- 6 Breakoutbox P01

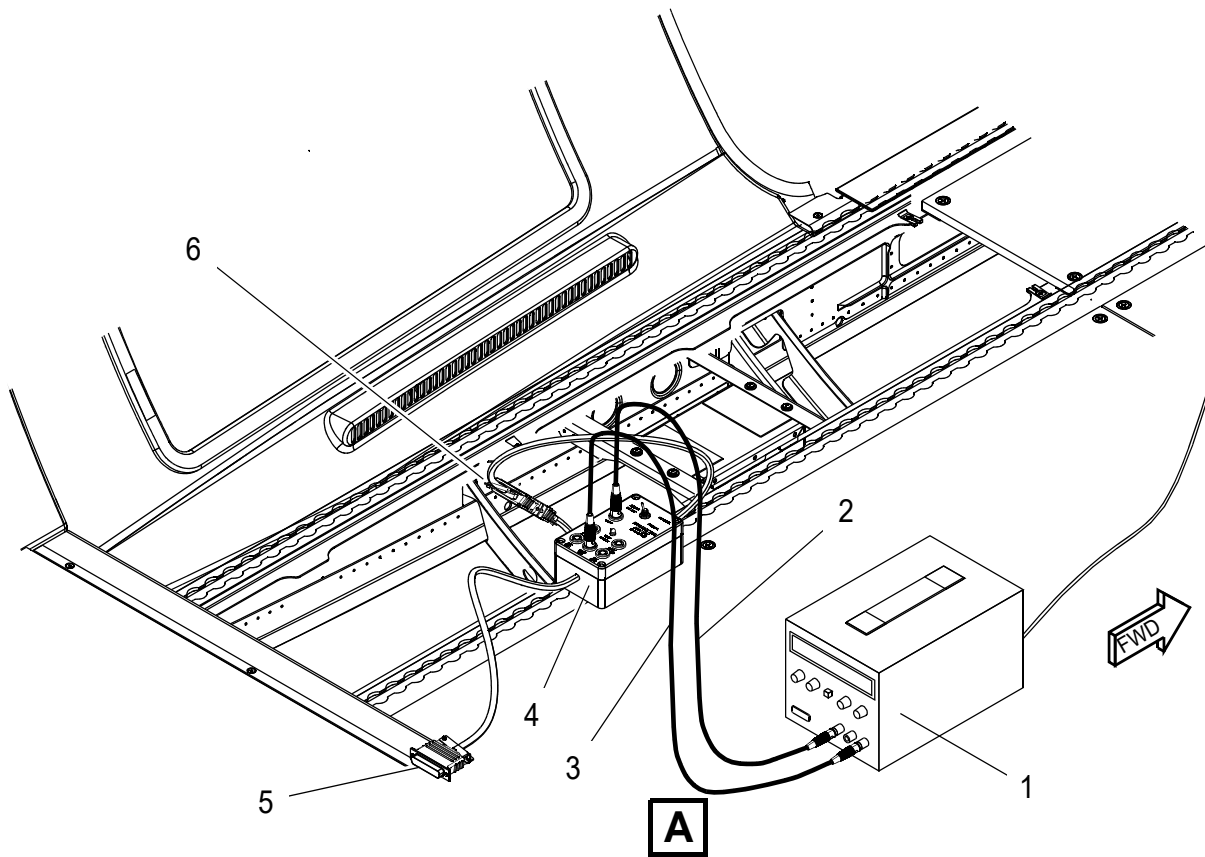

(ROTATED FOR CLARITY)

Figure 8. ABS/WST Breakout Box Connected to Ships Harness only

5202056A

## Method 3

- (1) Power Supply and RMS Multimeter connected to ships harness only.

Refer to [Figure 9](#).

- (a) Connect Power Supply and RMS Multimeter: as follows:

CAUTION: DO NOT EXCEED WST VOLTAGE RANGE  $5.0 \pm 0.3$  VOLTS. DAMAGE TO THE WST CAN OCCUR.

1. Setup power supply for output of +5VDC. Turn off power supply before connecting to the ship's harness connector 32A30P01.

CAUTION: MAKE SURE THAT THE +5VDC POWER SUPPLY LEAD IS CONNECTED TO THE CORRECT CONTACT ON 32A30P01, DAMAGE TO THE AIRCRAFT CAN OCCUR.

2. Connect power supply positive lead to 32A30P01, contact 44.
3. Connect power supply ground to 32A30P01, contact 30.
4. Connect RMS Multimeter negative lead to 32A30P01, contact 30.
5. Connect RMS Multimeter positive lead to 32A30P01, contact 39 (L) or contact 24 (R) which ever WST is under test

NOTE: Both the left and right WSTs can be monitor simultaneously by using two RMS Multimeters.

6. Set RMS Multimeter function to DC volts.
7. Turn power supply on.

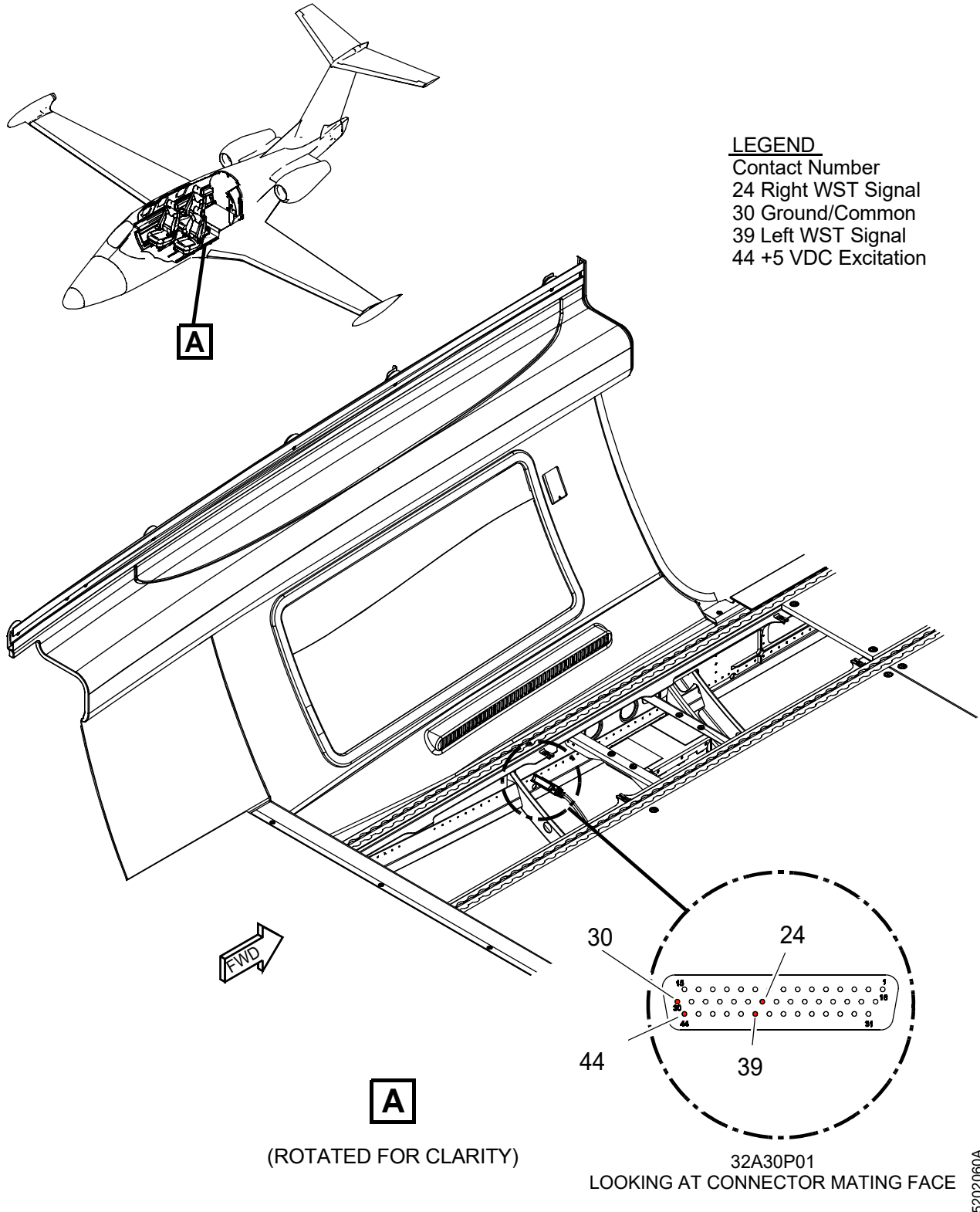

Figure 9. Power Supply and RMS Multimeter connected to ships harness only

## F. WST Functional Test

Typically the observed WST Signal Voltage will go from approximately 100milli-volt to 4.96 volts, then drops. The preciseness of this observed voltage is not important. What is important is that there is a voltage output that varies from near 0 to near the applied excitation (5 volts).

A bad WST unit will be stuck at a very low or 0 voltage or will not respond to shaft rotation.

Refer to [Figure 10](#).

NOTE: [Figure 10](#) shows both a RMS Voltmeter and an optional Oscilloscope connected to the Breakout Box.

- (1) Rotate the WST shaft slowly clockwise and observe that the voltmeter reading indicates a voltage that ramps up to ~5.0 volts, then suddenly changes to near 0 Volts with each revolution.

NOTE: If using Method 1 setup, the voltage reading at the WST SIG (L or R) jack will be approximately 4 volts due to the voltage drop from the diodes in the Breakout Box.

- (2) Carefully rotate tire, in either direction, until a voltage of less than 200 milli-volts is achieved.
- (3) Carefully rotate tire, in either direction, until a voltage of greater than 4.90 volts is achieved.

NOTE: If using Method 1 setup, the voltage reading at the WST SIG (L or R) jack will be approximately 4 volts due to the voltage drop from the diodes in the Breakout Box.

- (4) If the unit fails to achieve the voltage, reject the unit.

NOTE: The WST signal includes a carrier frequency of ~950Hz. This can be confirmed using the frequency function of a meter.

- (5) Repeat the test on the opposite side if a single RMS Multimeter is used.

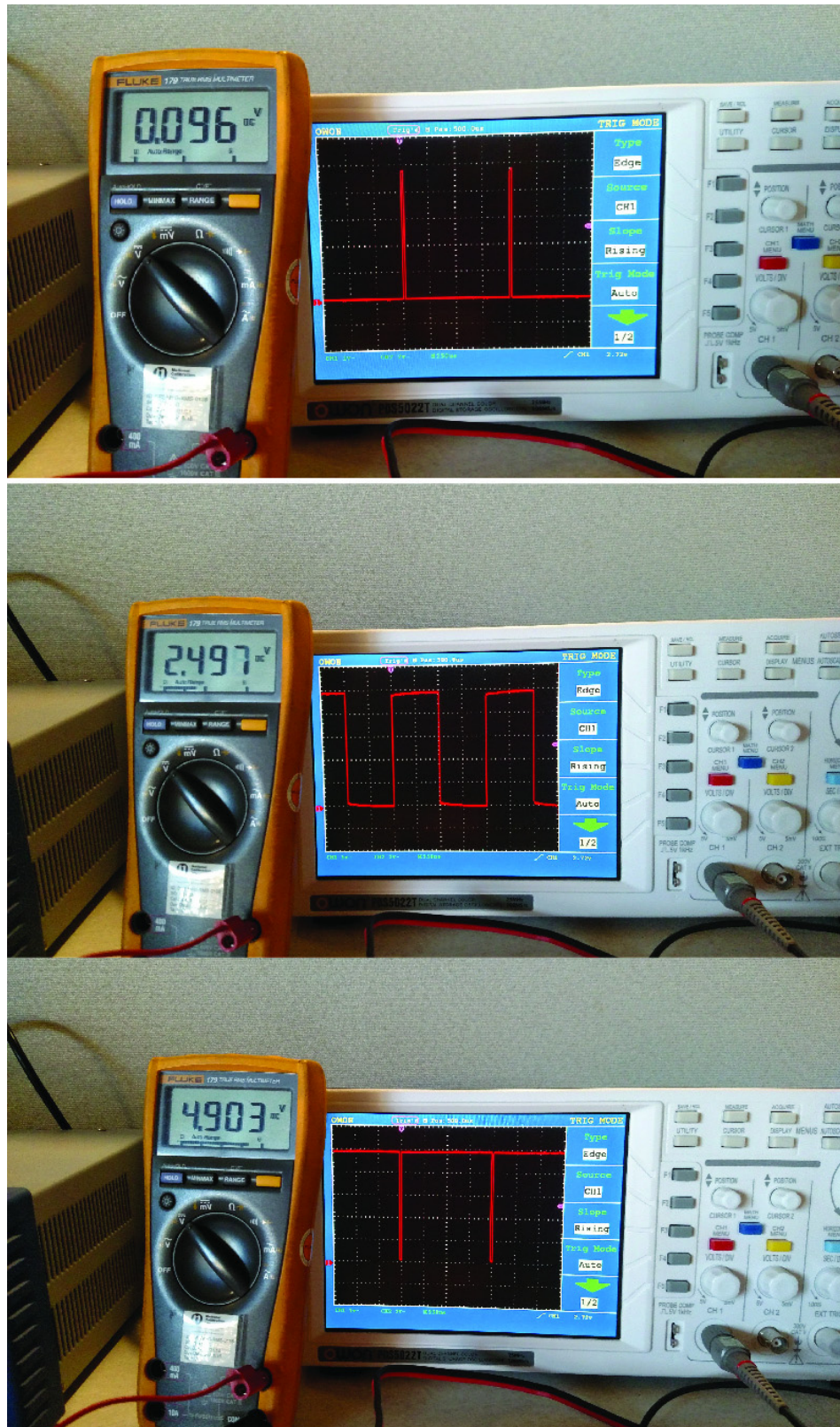

**Figure 10. Test with RMS Voltmeter & Oscilloscope**

## G. Job Close-Up

- (1) Turn off the power supply, if used.
- (2) Turn off aircraft power, if used.
- (3) Disconnect the RMS Multimeter leads and power supply leads (if used).
- (4) Disconnect ABS/WST Breakout Box (if used) and reconnect ships harness 32A30P01 to DECU connector 32A30J01,
- (5) Install 131 AZ - Floor Panel, Forward Left Cabin. Refer to AMM-06-50-00-051-801 – Aircraft Access Panels.
- (6) Install passenger seat. Refer to AMM-25-21-10-001-801 – Passenger Seat - Installation.
- (7) Lower the aircraft and remove the jacks. Refer to AMM-07-10-00-051-801 – Jacking -Maintenance Practices.
- (8) If all other maintenance is complete, return aircraft to service. Refer to AMM 20-00-02-051-801 RETURN TO SERVICE (AFTER MAINTENANCE).

## H. Limitations and Procedures

None

## I. Parts Disposition

N/A

## 4. RECORD OF COMPLIANCE

Upon completion of this Service Bulletin, make an appropriate maintenance-record entry specifying the Service Bulletin number.

## 5. NOTIFYING ECLIPSE AEROSPACE

On completing this Service Bulletin, the operator/maintainer shall complete the attached Compliance Record and send it to Eclipse Aerospace via regular mail, fax, or e-mail.

Mailing Address	Eclipse Aerospace Incorporated ATTN: Service Engineering 3520 Spirit Drive SE Albuquerque, NM 87106
Fax	1-505-241-8802
E-mail	sbcompliance@eclipse.aero

